

Introduction to Oxy-Acetylene Welding



School of the Art Institute
of Chicago



Welcome to the Columbus Metal Shop!

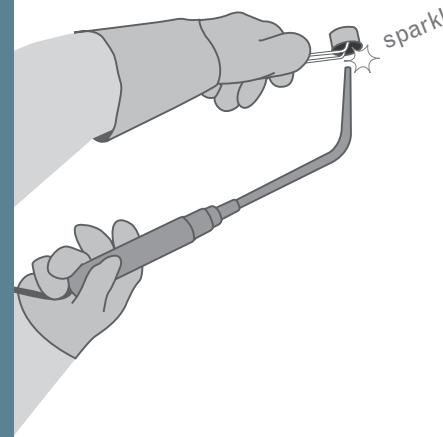

The School of the Art Institute's Columbus Metal Shop is one of four Instructional Fabrication shops at SAIC.

The Columbus Metal Shop is a general access facility set up to provide instruction and material resources for the School's students, faculty, and staff. The Metal Shop's facilities and unique instructional programs have been structured to meet the needs of students working on a wide range of projects.

The metal shop facilities include a wide range of hot and cold metal working equipment.



Cold working capabilities include

- drilling
- punching
- mechanical fastening
- roll forming
- bending
- shearing
- cutting
- grinding
- sanding
- abrasive blasting

Hot working capabilities include

- forging/annealing
- plasma cutting
- oxy-fuel welding & cutting
- shielded metal ARC welding
- gas metal arc welding (MIG)
- gas tungsten arc welding (TIG)



INSTRUCTIONAL FABRICATION

Instructional Fabrication's mission is to serve the contemporary art making needs of the School of the Art Institute of Chicago by providing instruction and technical assistance to students and faculty using the School's shops and fabrication facilities. Our staff work collaboratively across artistic and academic disciplines to support all manners of fabricating art objects.

Instructional Fabrication is a division within the department of Instructional Resources & Facilities Management (IRFM).

www.saic.edu/instructionalfabrication

6	Getting Ready
8	Equipment for Process : <i>Check Out From Cage</i>
10	Material <i>Concerns</i>
11	Material <i>Handling</i>
12	Welding Anatomy & Capability
14	Turning on Fuel
16	Turning on Fuel <i>continued</i>
18	Process : <i>Welding</i>
20	Process : <i>Cutting</i>
22	Closing Down : <i>Leaving Station</i>

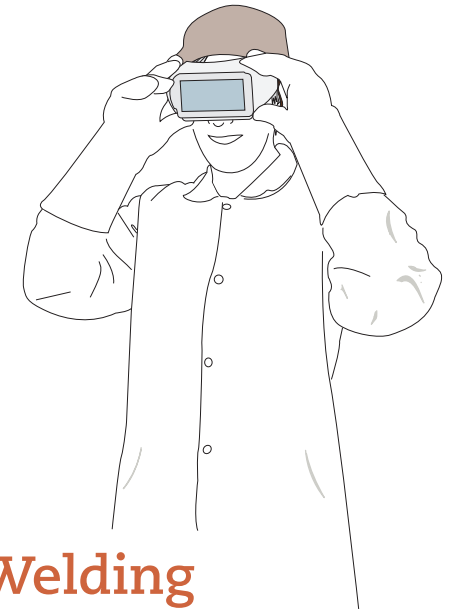

Introduction to **Oxy-Acetylene Welding**

Oxy-Acetylene, commonly known as Oxy-fuel, is one of the oldest welding processes, though in recent years, it has become less popular in industrial applications. However, it is still widely used for a variety of applications. Oxy-fuel equipment is versatile, lending itself to welding, brazing, braze-welding, silver soldering, metal heating (for bending and forming) and oxy-fuel cutting. This book will highlight the welding and cutting processes.

Getting Ready



Authorizations

In order to work in the Metal Shop, you must first attend an Authorization. Authorization Sign Up Sheets and Authorization Request Forms are posted adjacent to the tool checkout area in the Columbus Wood Shop, Room 024. It is highly recommended that new patrons complete the Introduction to Metal Working Authorization before participating in the welding authorizations.



Planning Your Project

(See also Material Concerns, page 10)

We encourage patrons to speak with the shop's staff about making material choices that best suit your projects before committing to a purchase—your choice of materials may limit what equipment will be available to you.



Flammable Combustibles Prohibited

Flammable Liquids are prohibited in the Metal Shop, including but not limited to butane lighters, propane, aerosol cans, and solvents. Use extreme caution when working near flammable materials (sketchbooks, backpacks, etcetera). Flames, sparks, and hot surfaces can cause fires.



Physical & Mental Condition

Stress, anxiety, sleep deprivation, low blood sugar, and drugs (prescription & recreational) will interfere with your ability to work safely.



Accessories

Remove all accessories that could conduct heat or get caught in moving parts of equipment: rings, piercings, watches, ID card lanyards, etcetera.



Hair

Tie hair back, tuck hair in jacket, or hold hair back with a bandanna. A cap is also a good idea.



Shirts

Choose natural fibers like cotton, hemp and wool to weld in. Synthetic fibers (polyester, nylon) are not recommended. You will be required to wear a welding jacket for all welding processes.



Pants

Choose natural fibers, no synthetic fibers (polyester, nylon). Holes or loose, frayed areas are prohibited. Cuff or roll in pant legs that touch the ground.



Shoes

Sturdy, closed-toe shoes. Leather shoes are highly recommended. No synthetic material, like material found on running shoes.

Equipment For Process: *Check out from cage*

Overview

Personal Protection Equipment

Eye Protection

Oxy Goggles are shaded to prevent radiation exposure—**shade value of 5 for Oxy, 10 for other welding processes**. Do not observe other welding processes with oxy goggles other than oxy fuel.

Welding Jacket

Flame Retardant Jacket is required for all welding processes.

Hand Protection

Welding Gloves are available in small, medium, and large. Gauntlet style welding gloves protect your hands from radiant heat—**do not use these gloves for handling material**.

Hearing Protection

Hearing protection is not required for oxy fuel. However, you may need them when someone near is noisy. In that case, use ear muffs. Foam plugs are not recommended. **NO HEADPHONES**.

Respiratory Protection

A Welding Fume Respirator is highly recommended for persons with respiratory concerns. The metal shop is equipped with an exhaust system that must be activated before using welding equipment.

REQUIRED

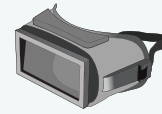

Welding Goggles



Welding Jacket



Welding Gloves

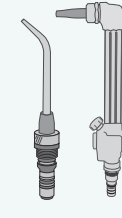

Welding Tip or Cutting Attachment



Striker



Filler Material

RECOMMENDED



Ear Muffs

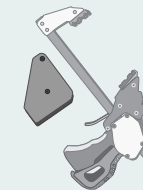

Magnetic Clamps & Fixtures

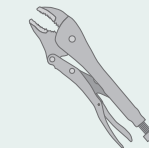

Locking Pliers



Wire Brush

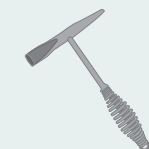

Slaghammer

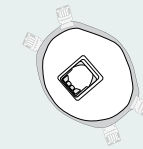

Welding Fume Respirator

A variety of shapes and dimensions are available for students to purchase with their ARTICard at the Columbus Resale Center, around the corner from the shops. Rod stock and tubing is available in rounds and squares, angle iron is available in a variety of dimensions, and sheet metal is available in common gauges (thickness).

Linear material is sold by the foot length or in some cases full lengths averaging 12 feet. Sheet metal is sold by the square foot, with a minimum purchase requirement of 4 square feet (24" X 24").

Types of Steel



Hot Rolled

- Grayscale on surface
- Clean with wire brush before welding

Cold Rolled

- Shiny, oily surface
- Clean with orange soap and paper towels before welding. Dispose of paper in red fire-proof can.

* Before welding, make sure to remove all oil used during the preparation and fabrication of materials.

How to Carry

A separate pair of gloves for material handling is recommended—DO NOT use Welding Gloves. Also, it is very important for your welding gloves to remain oil-free.

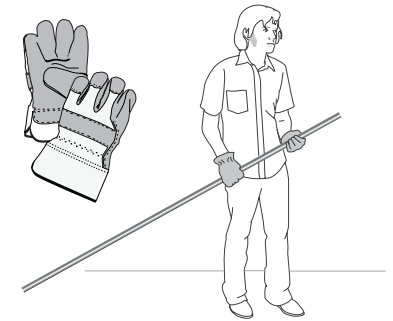

Use caution when entering & exiting doorways or blind intersections.

Do not try to carry long lengths or heavy material without help. Avoid walking in front of or behind materials, walk alongside.

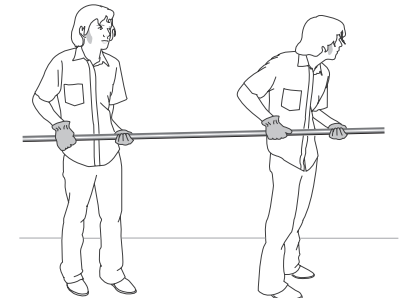

DO NOT weld on materials, including hardware, that contain:

- Paint
- Wax
- Chrome Plated or Galvanized Surfaces
- Magnesium
- Lead
- Rust
- Grease or Oil (burned oil is a carcinogen)

Reuse Bin

Material for the Reuse Bin must be approved by management.



Recycle Bin

Please refrain from tossing unusable material, recycle it.



Welding: Anatomy & Capability

A. Mixer

There are 8 mixing stations attached to the wall. This is your source for oxygen and acetylene fuel.

The mixer is where you will attach welding tips, cutting attachment, and the rosebud heating torch.

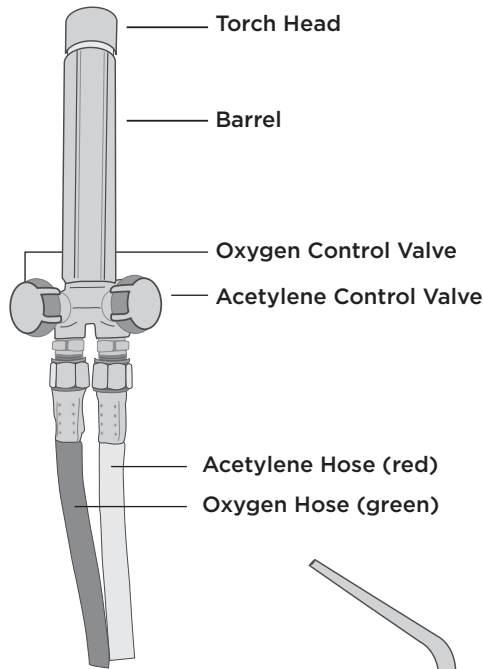

B. Welding Tips

There are 3 types of welding tips available: 1, 3, 5, and 9. Tip size will depend on type of filler material used, see below chart.

REGULATOR SETTINGS				
Material	Tip Size	Acetylene	Oxygen	Filler Rod
22-18 gauge	1	8 psi	8 psi	1/16"
16-14 gauge	3	8 psi	8 psi	3/32"
12-10 gauge	5	8 psi	8 psi	1/8"
1/4"-3/8"	9	8 psi	8 psi	3/16" *

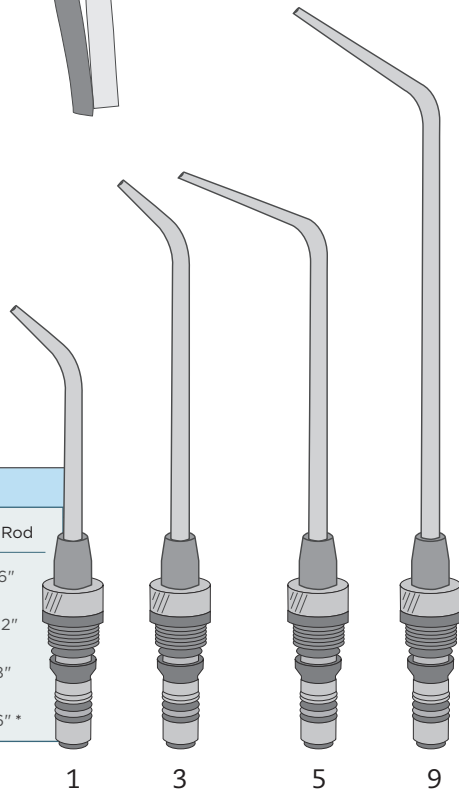

* 3/16" filler rod is not available through Resale.

C. Cutting Attachment

The cutting attachment simply functions as a convenient and economical approach to cutting steel. The cutting attachment can be used for material up to 3/4 of an inch thick.

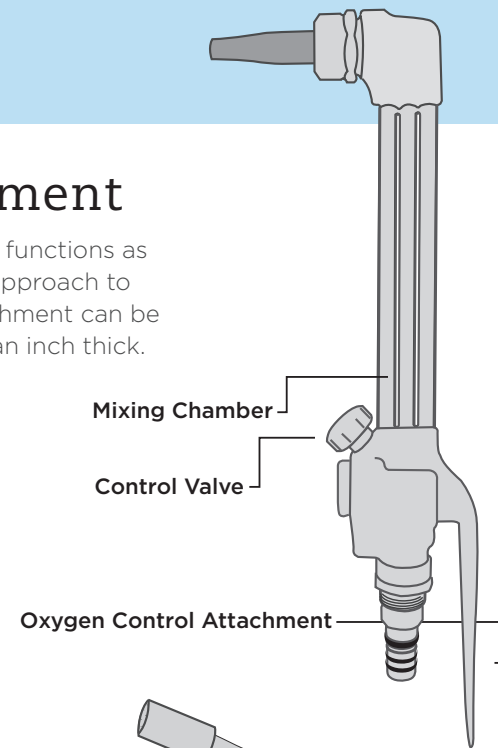

D. Rosebud Heating Tip

The Rosebud Heating Tip is used for *specific* heating applications. The Rosebud is a fuel intensive attachment that should be used with discretion. Please check with shop staff to see if it might be right for your project.

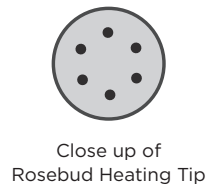

Turning On Fuel

1. Before you begin, perform Hover Test.

Place the back of your bare hand close to a work surface or tool before touching or setting down something heat sensitive.

Welding tables, stationary equipment, tools, and scrap material might not appear hot, but may be hot enough to injure you or damage equipment.



2. Take enough hose off hanger carefully so the mixer reaches the welding table without creating a tripping hazard.

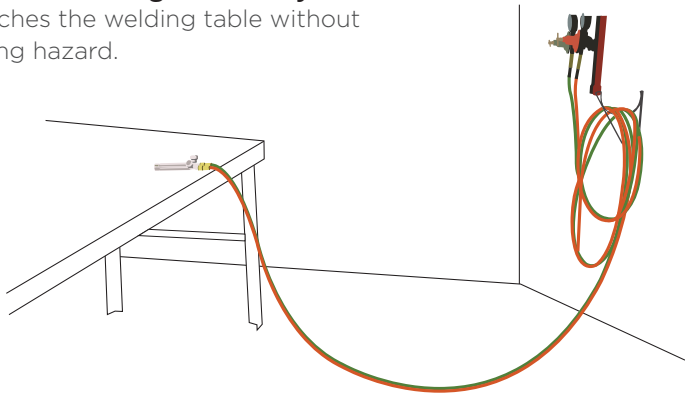

3. Inspect the hose for wear or damage by making your way from the torch handle to the regulators.

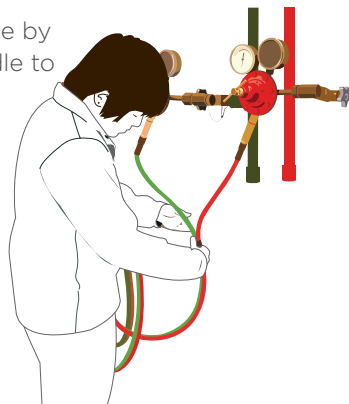

4. Install tip into mixer, hand tighten nut on top with touch tip facing to the left (for right hand use) or facing right (for left-hand use).

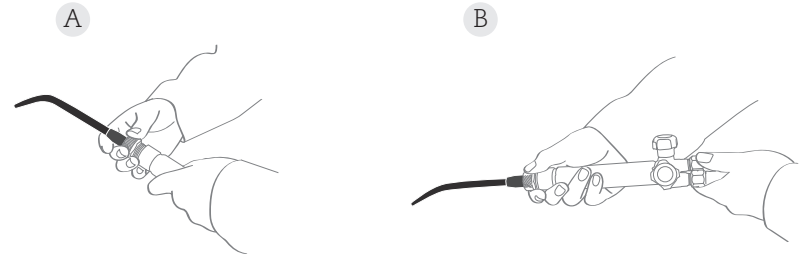

5. Check torch handle to make sure it is closed by gently turning knobs counter clockwise to open and then clockwise to completely close.

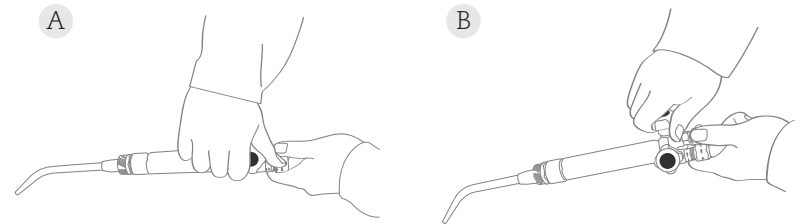

6. Check regulator keys to make sure they are backed out (disengaged) and approximately 1/2 inch of threads are exposed.

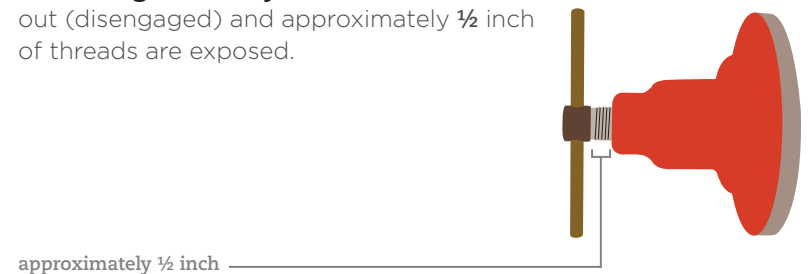

Turning On Fuel *continued*

7. **Standing to the side of regulators**, open both oxygen and acetylene shut-off valves slowly by turning counter-clockwise until fully opened, then close ½ turn clockwise.

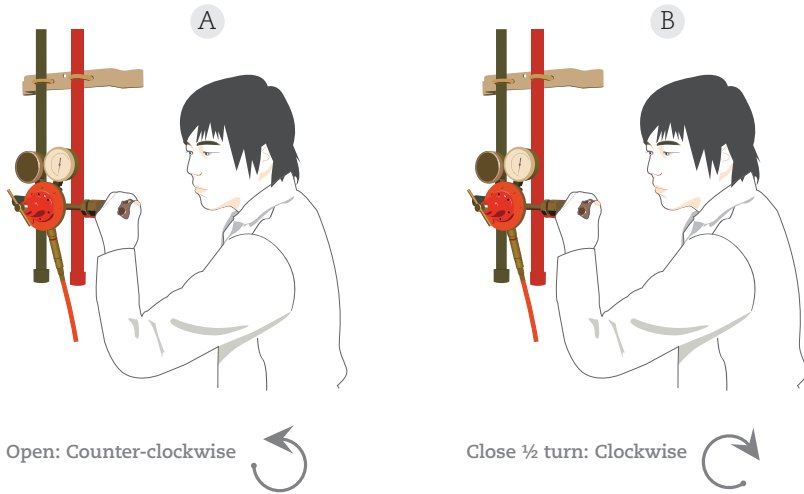

8. **Open acetylene (red) and oxygen (green) mixer valves ¼ turn** while directing welding tip towards exhaust. Turn regulator key clockwise until **5 psi** registers on regulator gauge, always reading in red. Then close mixer valve.

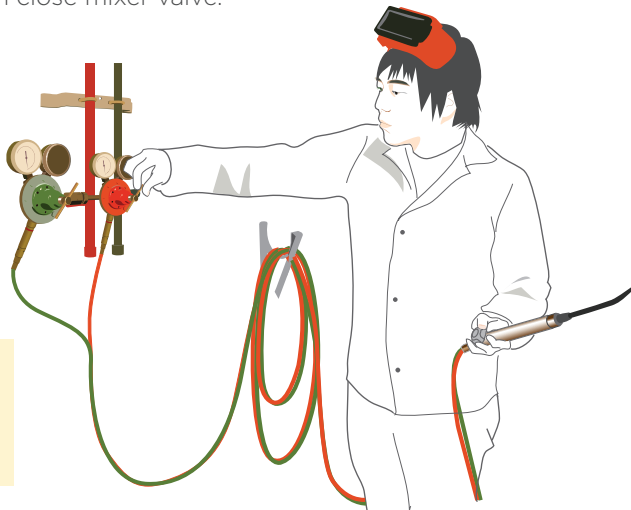

Ratio 1:1
1 part acetylene
to 1 part oxygen

9. **Before the torch is lit**, put on welding gloves and oxygen-acetylene goggles.

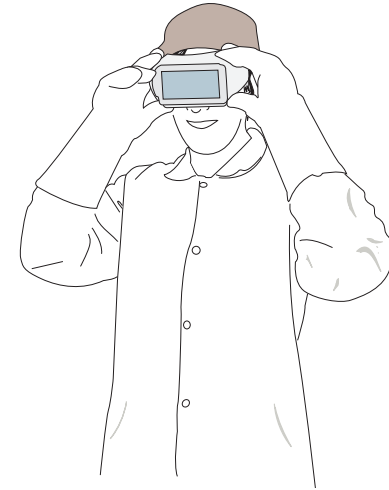

Oxygen Number Increments: 5, 10, 15, 20

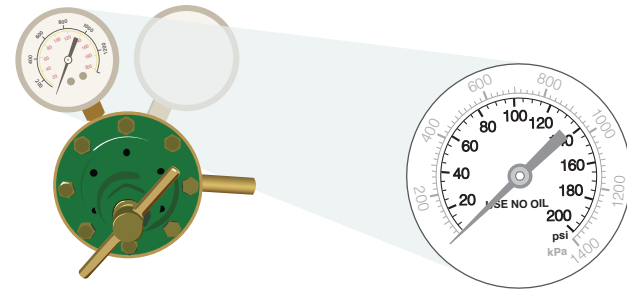

Acetylene Number Increments: 1, 2, 3, 4, 5

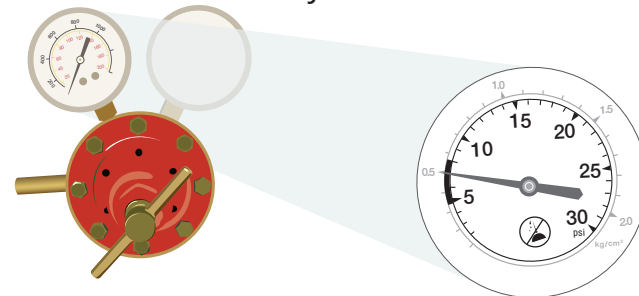

Process: *Welding*

Purge fuel by opening torch knob and allow a 3-5 second flow. Then close the fuel gas valve. Purging must take place each time prior to igniting the torch flame.

Light the Torch

1. Direct torch away from you, towards the ventilation.

2. Open acetylene control valve on mixer, approximately $\frac{1}{8}$ turn rotation counter-clockwise.

3. Light with striker. Never use lighters or other sources for ignition.

* Always position yourself with fresh air at your back so fumes are drawn away from you, not past you.

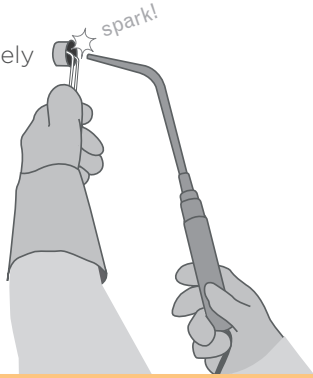

Adjust the Flame

4. Adjust acetylene to form feather shaped flame.



If there is too much acetylene, flame breaks away from the tip. Slowly add oxygen—flame will sharpen and elongate.



Continue to add oxygen



until neutral flame is established.



And Weld!

5. Focus green cone's tip (neutral flame) onto area you are welding.
6. Maintain a consistent distance from material, heating a narrow path between two materials.
7. After puddle is established, introduce filler rod.
8. Melt filler rod into puddle and move along, establishing a weld path, often called a bead.

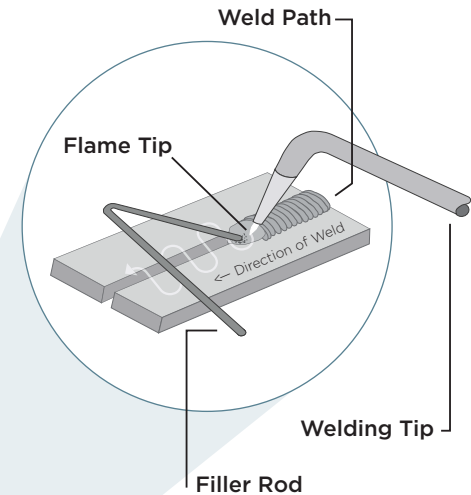

Process: *Cutting*

A. Prepare Equipment

1. **Inspect cutting attachments** before use. If there appears to be grease, oil, or equipment damage, return tools to the cage and exchange for a working replacement.
2. **Insert cutting attachment** into the torch handle and hand tighten the connection nut.
3. **Adjust oxygen** regulator to the pressure setting relative to material size, see tip chart below. Then open oxygen valve on torch handle.
4. **Adjust acetylene** regulator to **10 psi**. Then open acetylene valve on torch handle.
5. **Purge fuel** by opening torch knob and allow a 3-5 second flow. Then close the fuel gas valve. Purging must take place each time prior to igniting the torch flame.

REGULATOR SETTINGS			
Material	Cutting Tip Size	Acetylene	Oxygen
Up to 10 gauge	000	8 psi	20 psi
Up to 3/16"	00	8 psi	20 psi
Up to 1/4"	0	8 psi	30 psi
Up to 3/8"	0	8 psi	35 psi
Up to 1/2"	0	8 psi	35 psi
Up to 5/8"	0	8 psi	40 psi

B. Ignite Flame

1. **Open acetylene valve** on torch $1/8$ turn and light with striker.
2. **Open oxygen valve** and flame should appear, also known as acetylene feather. Continue to add oxygen and reduce feather until neutral flame is established.
3. **Establish puddle** by maintaining a consistent distance from material, heating a narrow path (same as welding).
4. **Depress oxygen lever** and move to make cut.

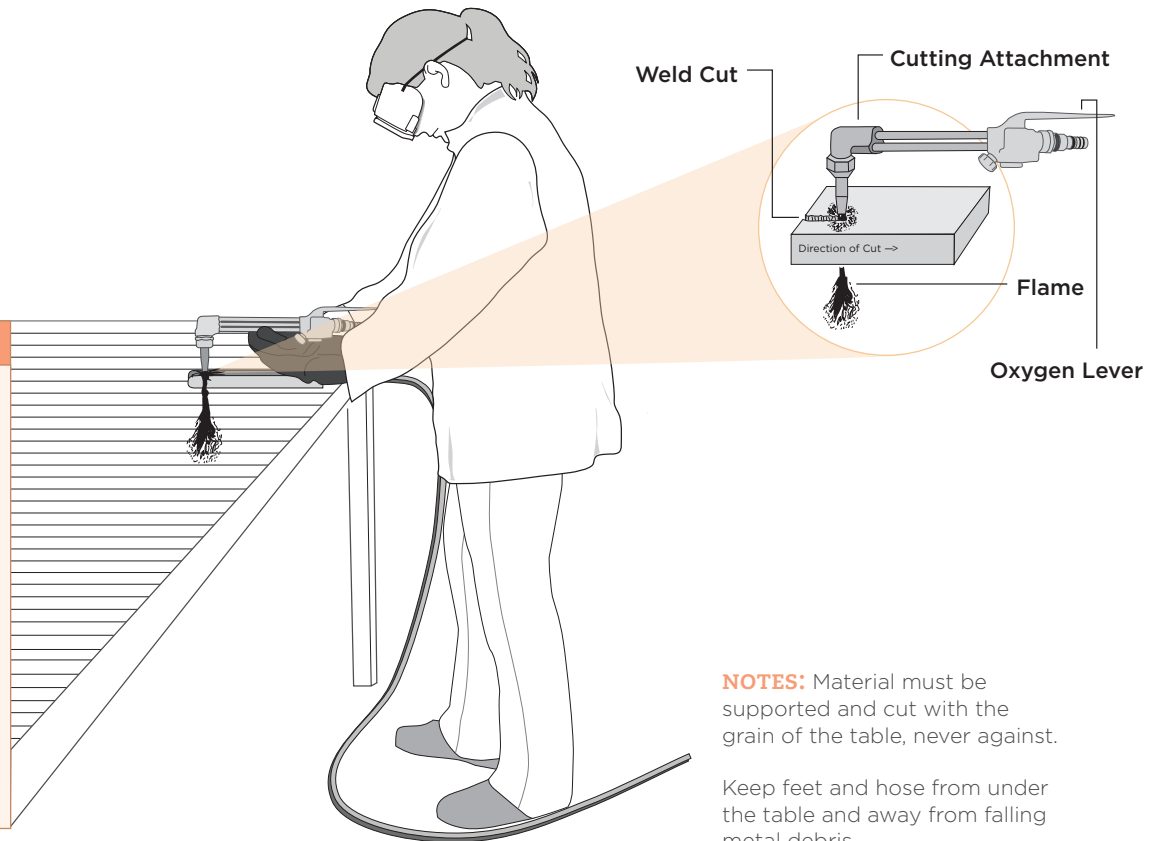

NOTES: Material must be supported and cut with the grain of the table, never against.

Keep feet and hose from under the table and away from falling metal debris.

Closing Down: *Leaving Station*

- 1. Extinguish flame** by first closing oxygen at mixer. Turn torch handle knob counter-clockwise. Repeat process to close acetylene at mixer.

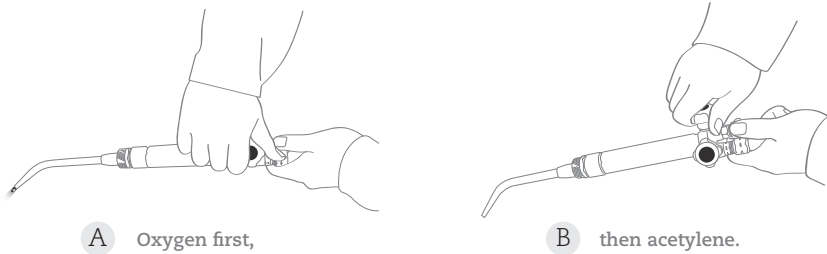

- 2. Close shut-off valves** for oxygen & acetylene by turning clockwise.

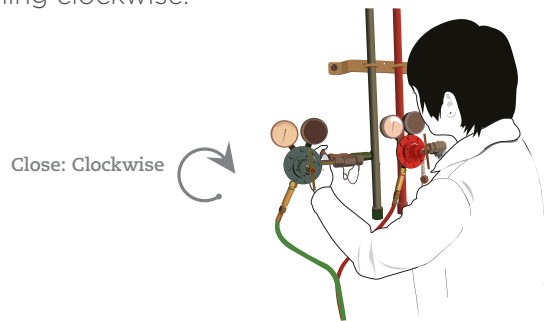

- 3. Bleed the line.** Open acetylene at mixer and allow fuel to empty for a few seconds, a process known as bleeding the line. Then close acetylene at mixer. Repeat for oxygen.

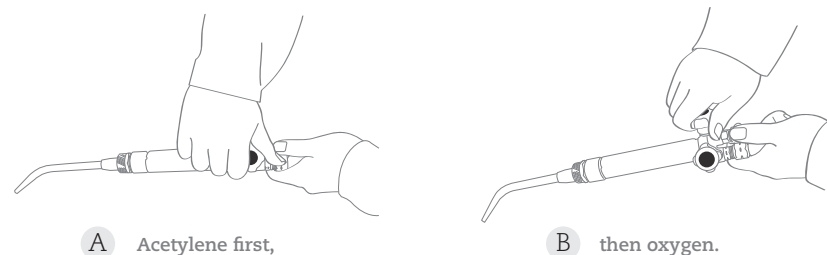

- 4. Back out regulator keys** on oxygen & acetylene regulators, exposing approximately $\frac{1}{2}$ inch of threads.

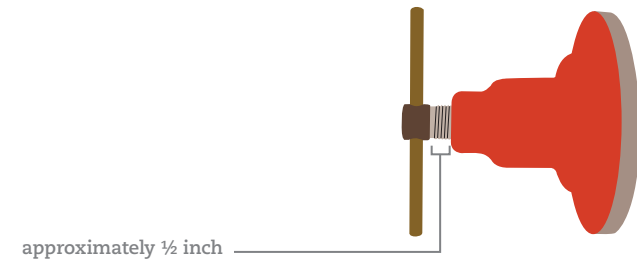

- 5. Take tip off,** be careful of temperature. Allow tip or attachment to cool before returning to cage!

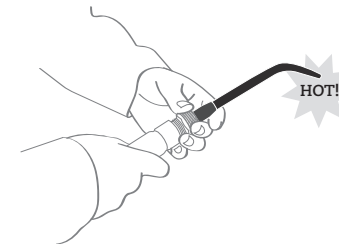

- 6. Hang hose** up on wall rack in large, neat loops. Return all the equipment back to the cage.



End Comments

Please do not hesitate to ask for help. If you are not absolutely certain about what you are doing, or if you are having difficulty with any aspect of the process we can help.

If the equipment is not working properly or appears to be damaged stop immediately and seek shop staff.

General Principles in Welding Steel

- A well balanced neutral flame is used for welding most steels. To be sure the flame is not oxidizing, it is sometimes used with a slight acetylene feather. A very slight excess of acetylene may be used for welding alloys with a high carbon, chromium, or nickel content. However, increased welding speeds are possible by using a slightly reduced flame. Avoid excessive gas pressure because it gives a harsh flame. This often results in cold shuts or laps, and makes molten metal control difficult.
- The tip size and volume of flame used should be sufficient to reduce the metal to a fully molten state and to produce complete joint penetration. Care should be taken to avoid the formation of molten metal drip heads from the bottom of the joint. The flame should bring joint edges to the fusion point ahead of the puddle as the weld progresses.
- The pool of the molten metal should progress evenly down the seam as the weld is being made.
- The inner cone tip of the flame should not be permitted to come in contact with the welding rod, molten puddle, or base metal. The flame should be manipulated so that the molten metal is protected from the atmosphere by the envelope or outer flame.
- The end of the welding rod should be melted by placing it in the puddle under the protection of the enveloping flame. The rod should not be melted above the puddle and allowed to drip into it.